

















Ledklok PHB2 is de referentie voor het verlichten van industriële ruimten of magazijnen. PHB2 is voorzien van een IP65 behuizing met geïntegreerde ventilatiesleuven voor een optimale koelin en uitgerust met performante SMD3030 leds en een dimbare 1-10V kwaliteitsdriver met lange levensduur. PHB2 is standaard voorzien van een mat polycarbonaat cover. Toestelrendement tot 130lm/W bij 4000K, standaard lichtbundel van 110°. Met de optionele muurbeugel is het mogelijk om het toestel in een vaste positie te monteren op wand of plafond. Versie CTA kan door middel van dip switches ingesteld worden op 3000 of 5000K en op 100, 150 of 200W.

														
IP65	IK08	110	5	tot 130	0,95	70.000 L80B10	JA	>80	3000-5000	1-10V	EMC3030	34	JA	JA

Technische eigenschappen

Referentie	PHB2PCTA
EAN code	5420076271060
ETIM code	EC001716

Elektrische eigenschappen

Systeem vermogen (W)	200
LED vermogen (W)	186
Aansluitspanning (Vac)	200-240
Frequentie (Hz)	47-63
Driver inbegrepen	ja
Driver intern/extern	intern
Driver merk	TCL
Driver type	200R
Dimbaar	1-10V
Flicker free	ja
Power factor	0,95
THD	<15%
Driver output (V)	
Driver output (mA)	
Isolatieklasse	I
Energie klasse	A+*
Aantal op 16A B curve	
Aantal op 16A C curve	6
Aantal op 16A D curve	9
Inrush current driver	70A

Garantie en certificatie

ENEC	ja
Garantie (jaar)	5 (exclusief batterijen)

Lichttechnische eigenschappen

Lichtbundel(°)	110
Kleurtemperatuur (K)	3000-5000
Kleurweergave CRI	>80
UGR	34
Kleurvastheid SDCM	<5
Lumen output (Lm)	27000
Lm/W	130
Flux code	
Ledchip	EMC3030
Ledfabrikant	Tiandian
Aantal LEDs	414
Fotobiologische klasse	RG1

Afmeting en materiaal eigenschappen

Afmetingen (LxBxH)	320x320x188mm
Gewicht (kg)	4,3
Kleur	zwart
Werktemperatuur (°C)	-30~+45
IP waarde	IP65
IK waarde	IK08
UV bestendig	ja
Zeewater bestendig	nee
UL 94	
Aantal in bulk	1
Aantal op pallet	42
Minimum bestelaantal	1
Stockartikel	ja

Lumen distribution

LUMINOUS INTENSITY DISTRIBUTION DIAGRAM

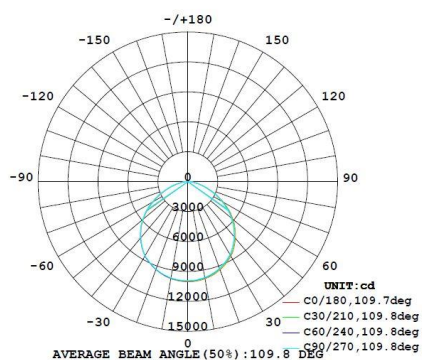

Distance curve:



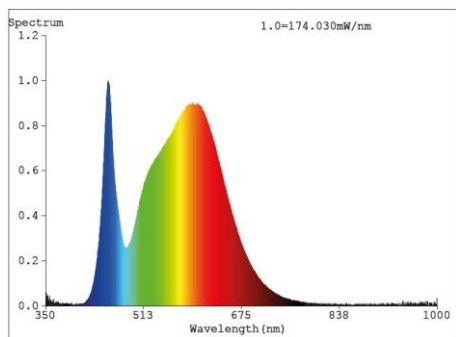

Spectrum distribution

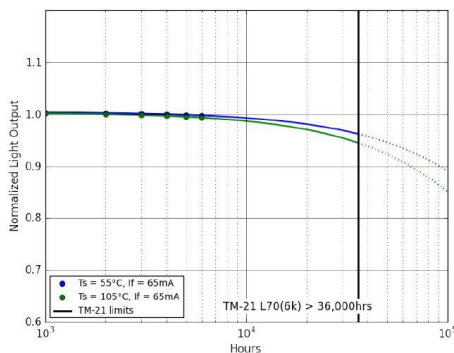

Lumendrop



Accessoires

PHB2200-PCC	Reflector prisma 100gr PHB2 200W	
PHB2200-COV	Afschermkap prisma reflector PHB2 200W	
PHB-WBR	Bevestigingsbeugel voor PHB/PHBP	
IP68-connect	Verbindingsset 3-polig IP68 2,5mm ² male-female	

Afmetingen

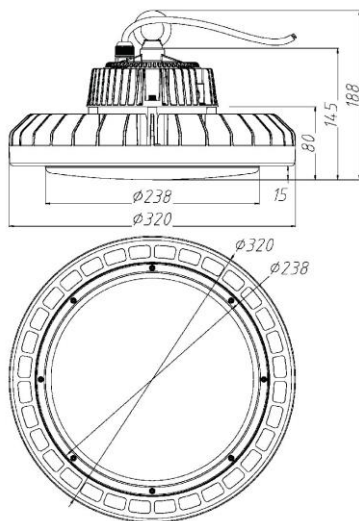

Aansluitschema



Isolation test 3,75KVac

TUV, GS, CB, D Mark, C