

Description:

Kit de connexion 3 poles 2,5mm² male/female



IP68



2 ANS

Kit de connexion IP68 avec connecteur 3 poles IP68 male/female 4mm². Convient pour le raccordement du IBL, HBRO, UBOAT.

Specifications technique

Référence	IP68-connect
EAN code	5420076210304
ETIM code	EC002556

Garantie et certification

Garantie (ans)	2
----------------	---

Dimensions et caractéristiques du matériau

Dimensions (LxlxH)	130x20x20mm
Diam. extérieur (mm)	
Diam. trou (mm)	
Poids (kg)	0,1
Couleur	noir
Valeur IP	IP68
Nombre en vrac	1
Nombre sur palette	
Quantité minimum	1

Dimensions

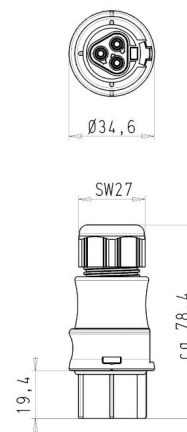

RST 16i2...5

Steckverbinder 2- bis 5-polig
2- to 5-pole Connector

Wieland Electric GmbH
Brennerstraße 10-14
96052 Bamberg
Tel. +49 (951) 9324-0
Fax +49 (951) 9324-198
Internet: www.wieland-electric.com
Email: info@wieland-electric.com



Wichtige Information - bitte aufmerksam lesen

Dieses Beiblatt beschreibt die Montage der 2- bis 5-poligen RST-Steckverbinder. Bitte beachten Sie, daß elektrische Anschlüsse und Installationen ausschließlich von hierfür ausgebildeten Fachkräften vorgenommen werden dürfen.

- Zusätzliche technische Hinweise unter www.wieland-electric.com

- Beachten Sie die jeweiligen länderspezifischen Installationsvorschriften.

Important information - please read carefully

This leaflet is intended for use by trained electricians only. It describes the mounting of the 2- to 5-pole RST connectors. Please observe the warnings and notes.

- Related technical information is available at www.wieland-electric.com

- The local erection rules have to be considered.

Schraubanschlüsse / Screw terminations

	Einfach-Anschluss / Connector	
Leiter / conductor	PE	N, L, 1, 2, 3
Abmantellänge y (mm) / Dismantling length y (mm)	33	25
Abisolierlänge x (mm) / Stripping length x (mm)	8	8

Leiterquerschnitt / Conductor diameter	feindrähtig / fine stranded	eindrähtig / solid
2-, 3-polig / 2-, 3-pole	0,25 – 1,5 mm ² (bis 1,0 mm ² mit Aderendhülsen verwendbar / up to 1,0 mm ² usable with ferrules.)	0,20 – 1,5 mm ²
4-, 5-polig / 4-, 5-pole	0,25 – 2,5 mm ² (bis 1,0 mm ² mit Aderendhülsen verwendbar / up to 1,0 mm ² usable with ferrules.)	0,20 – 2,5 mm ²

Abmantellängen und Abisolierlängen (mm) / Dismantling and Insulation strip lengths (mm)

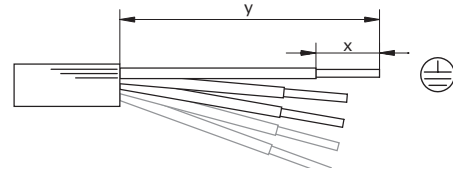

EN



DE

RST16 auf on YouTube



EN



DE

wieland eShop



EN



DE

wieland-electric.com

Leitermontage / Wire connection

Leitermontage / Wire connection

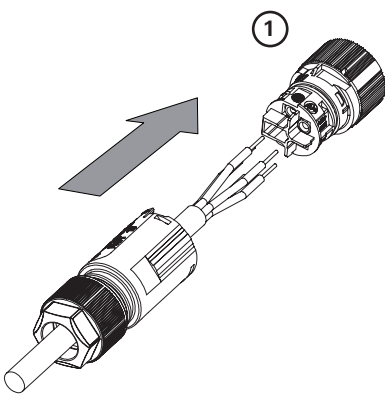

Darstellung beispielhaft. Gilt für 2- bis 5-polige Steckverbinder.
Example displayed relates to 2- to 5-pole connectors.

Schraubendreher

- Schneide DIN 5264 A, geschliffen
- Antrieb PZ1
- Anzugsmoment:
2-, 3-polig: 0,4 Nm
4-, 5-polig: 0,5 Nm

Screwdriver

- edge acc. to DIN 5264 A, deburred
- drive PZ1
- tightening torque:
2-, 3-pole: 0,4 Nm
4-, 5-pole: 0,5 Nm

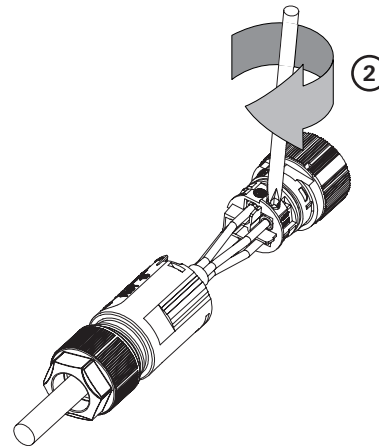

Verschließen / Closing

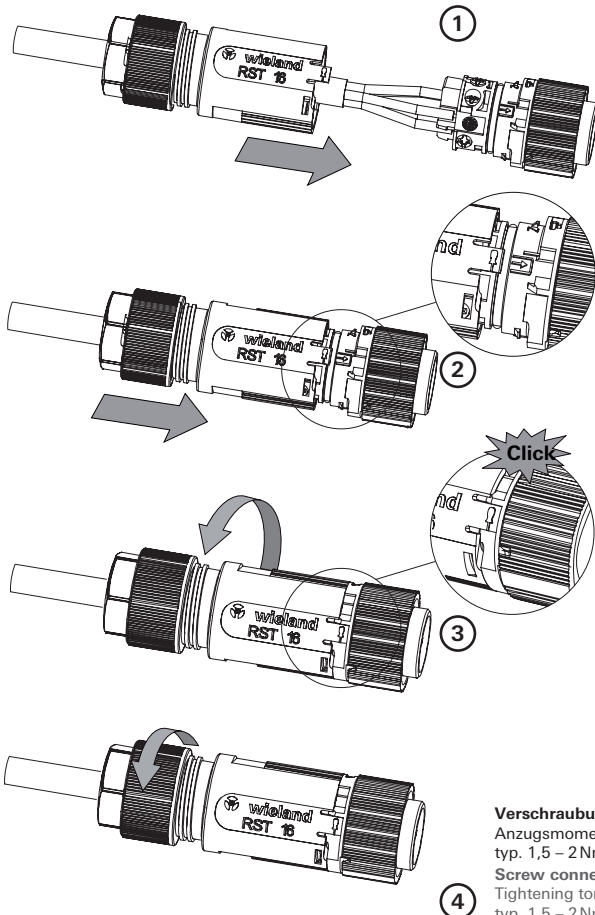

Verschraubung:

- Anzugsmoment typ. 1,5 – 2 Nm
- Screw connection: Tightening torque typ. 1,5 – 2 Nm

Öffnen des Steckverbinders / Opening the connector

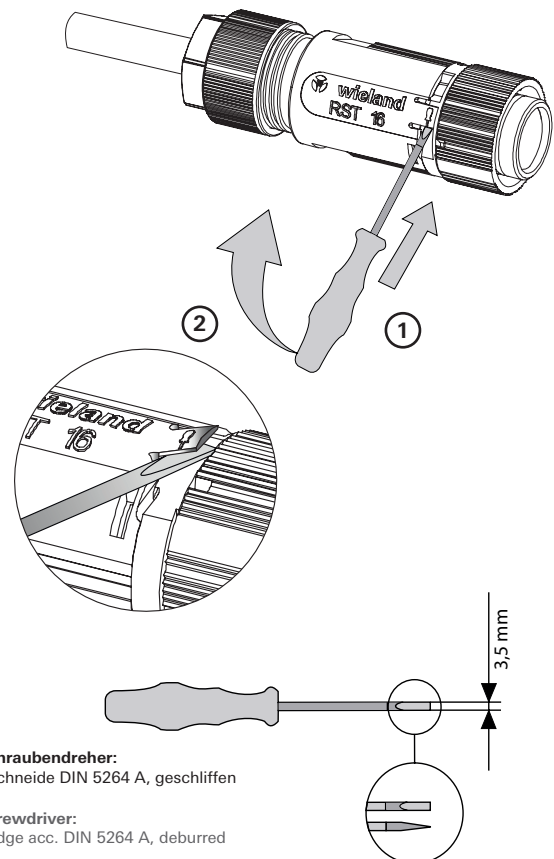

Schraubendreher:

- Schneide DIN 5264 A, geschliffen

Screwdriver:

- Edge acc. DIN 5264 A, deburred

Montage der Steckverbindung / Mounting the connector

RST 16i2...5

Steckverbinder 2- bis 5-polig
 2- to 5-pole Connector

Stecken und Verriegeln / Plugging and locking

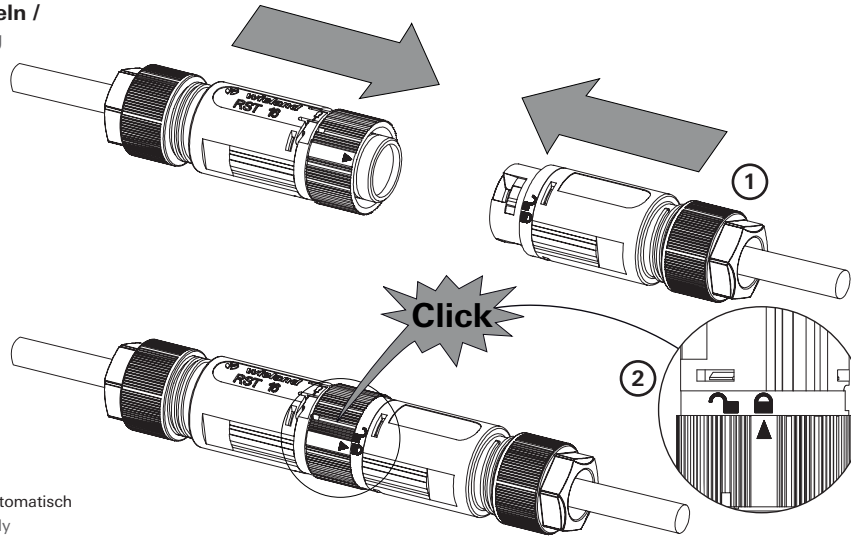

Steckverbinder verriegeln automatisch
 Connectors lock automatically



EN



DE

RST16 auf/on YouTube

Schließen der Steckverbindung /
 Closing of the connector

Entriegeln und Trennen / Unlocking and separating

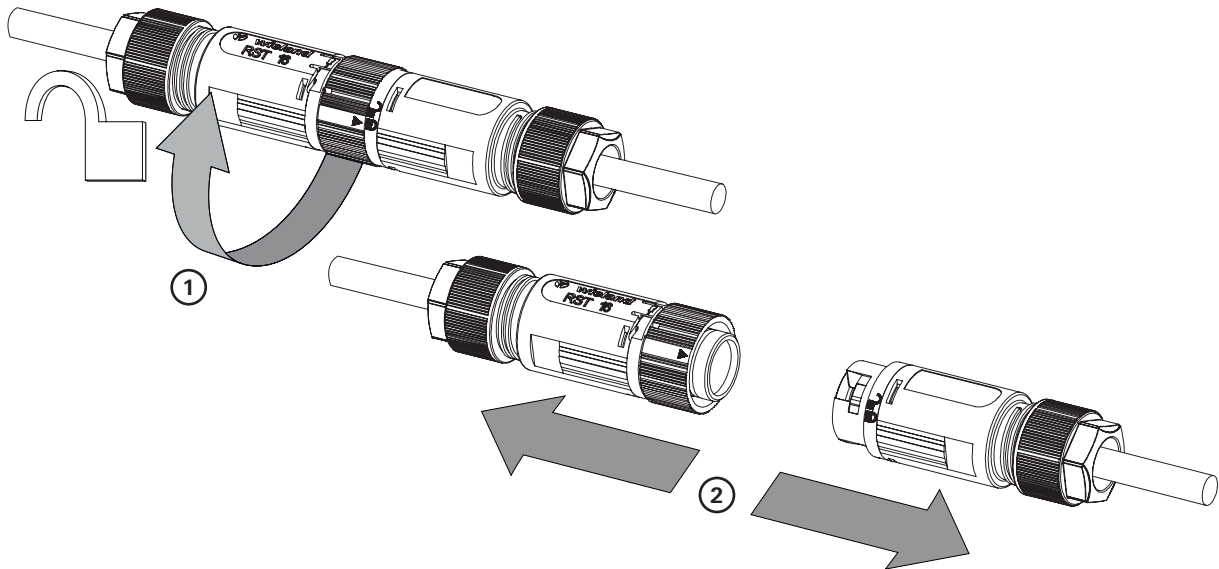

Öffnen der Steckverbindung /
 Opening the connector



EN



DE

wieland eShop

Gehäuseeinbau / Housing installation

Mutter:
 Anzugsmoment
 typ 1,5 Nm

Nut:
 Tightening torque
 type 1,5 Nm

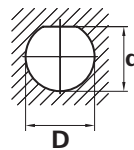
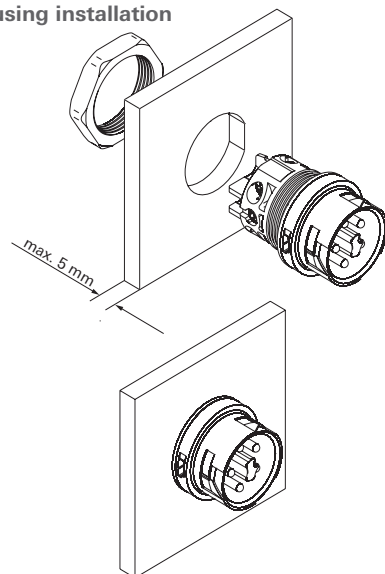

(wenn Verdrehschutz gewünscht ist)
 (protection against twisting)

	D (mm)	d (mm)
RST16 2-,3-polig/pole	16,2 \pm 0,1	14,6 \pm 0,1
RST16 4-,5-polig/pole	20,4 \pm 0,1	19,4 \pm 0,1



EN



DE

Montage der Gehäuseeinbauvarianten /
 Installing different housings

wieland-electric.com

Hotline:

Tel.: +49 (951) 9324-996 | Fax: +49 (951) 9326-996

Email: BIT.TS@wieland-electric.com | Internet: www.gesis.com

©2017 Wieland Electric GmbH. Alle Rechte vorbehalten. Fremdprodukte werden stets ohne Vermerk auf Patentrechte genannt. Die Existenz solcher Rechte ist daher nicht auszuschließen. Änderungen jeglicher Art an den genannten Produkten in Hard- oder Software haben einen Haftungsausschluss von Seiten des Herstellers zur Folge.

©2017 All rights reserved. This description, including all the diagrams, is protected by copyright. Third-party products are named without noting patent rights. The existence of these rights must therefore not be ruled out. Changes of any type that are made in the hardware or software of the products described result in an exclusion of liability on the part of the manufacturer.